

LEADER IN BAGGING EQUIPMENTS



Technipes

FUTURA

FUTURA

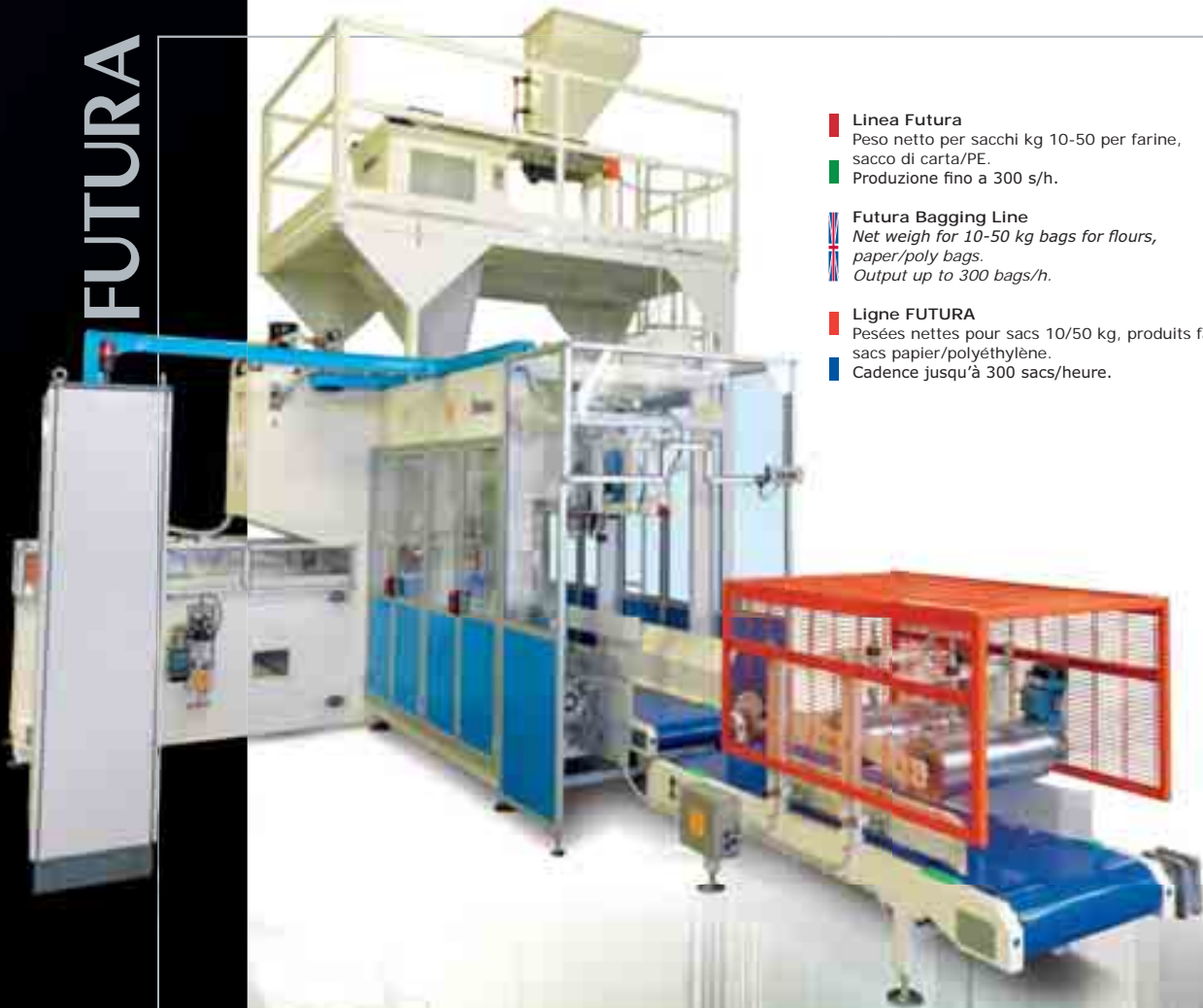

Linea Futura
Peso netto per sacchi kg 10-50 per farine,
sacco di carta/PE.
Produzione fino a 300 s/h.

Futura Bagging Line
Net weigh for 10-50 kg bags for flours,
paper/poly bags.
Output up to 300 bags/h.

Ligne FUTURA
Pesées nettes pour sacs 10/50 kg, produits farine,
sacs papier/polyéthylène.
Cadence jusqu'à 300 sacs/heure.



Technipes



Linea Futura
 Peso lordo per sacchi kg 10-50, prodotti polveri, sacco di carta. Produzione fino a 180 s/h.
 Sonda disaerazione prodotto a richiesta.

Futura Bagging Line
 Gross weigh for 10-50 kg bags, powdered products, paper bags. Output up to 180 bags/h.
 Optional deaeration probe.

Ligne FUTURA
 Pesées brutes pour sacs 10/50 kg, produits poudre sacs papier, cadence jusqu'à 180 sacs/heure, sonde de désaération produit sur demande.



Linea Futura
 Peso netto per sacchi kg 10-50, prodotti granulari/sfarinati, sacco di carta/PE.
 Produzione fino a 600 s/h.

Futura Bagging Line
 Net weigh for 10-50 kg bags, granulated/powdered products, paper/poly bags
 Output up to 600 bags/h.

Ligne FUTURA
 Pesées nettes pour sacs 10/50 kg, produits granulés/poudre, sacs papier/polyéthylène,
 cadence jusqu'à 600 sacs/heure.



Linea Futura
 Peso netto per sacchi kg 25-50, prodotti farine, sacco di raffia PP.
 Produzione fino a 450 s/h.

Futura Bagging Line
 Net weigh for 25-50 kg bags, flour products, woven PP bags.
 Output up to 450 bags/h.

Ligne FUTURA
 Pesées nettes pour sacs 25/50 kg, produits farine, sacs polypropylène, cadence jusqu'à 450 sacs/heure.

MF

Magazzino fisso a singola stazione
Fixed single station magazine - Magasin sacs vides à une pile



MM

Magazzino motorizzato a 2 o più posizioni
Powered magazine with two or more stations
Magasin sacs vides motorisé à deux ou plusieurs piles



MTR

Magazzino con traslatore sacco singolo
Magazine with single bag conveyor - Magasin de transfert sac vide

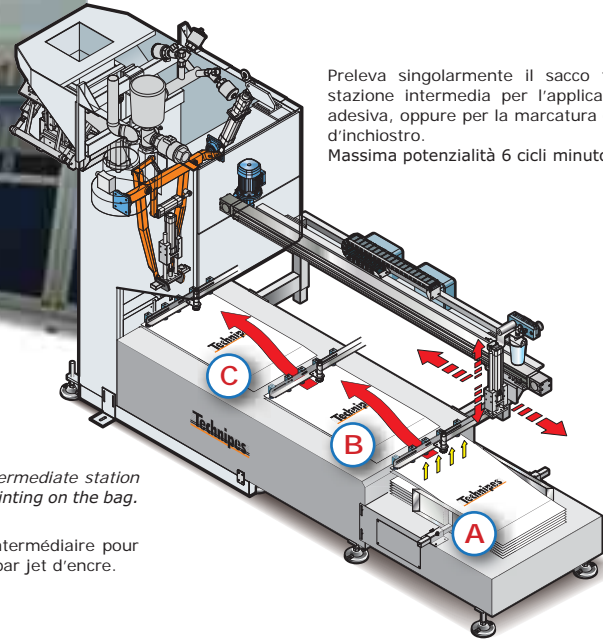

Preleva singolarmente il sacco trasladolo in una stazione intermedia per l'applicazione dell'etichetta adesiva, oppure per la marcatura del sacco con getto d'inchiostro.
 Massima potenzialità 6 cicli minuto.

Picks up a single bag and transfers it to an intermediate station for the application of an adhesive label, or for printing on the bag. Maximum capacity: 6 cycles per minute.

Préleve sac vide et transfert sur une station intermédiaire pour appliquer une étiquette adhésive et marquage par jet d'encre. Cadence 6 cycles/minute.

MSF

Magazzino con sfogliatore sacco - Magazine with bag dispensing system
Magasin dépileur de sacs vides

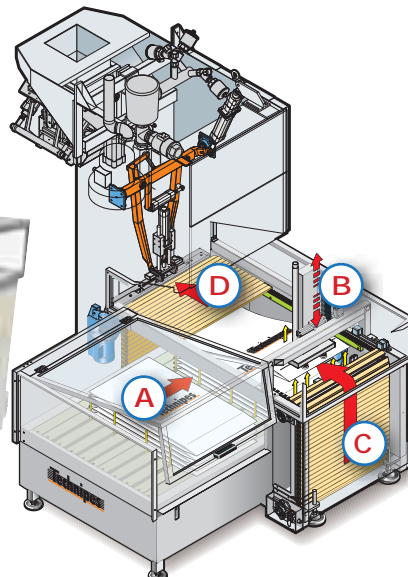

Indicato per sacchi di raffia polipropilenica. Preleva singolarmente il sacco dal fondello, successivamente una tapparella motorizzata sfoglia il sacco portandolo sulla stazione d'apertura della bocca. Massima potenzialità fino a 500 sacchi/h.

For use with woven PP bags. Dispenser picks up bag bottom, allowing powered slat conveyor to slide under bag and transfer to the bag mouth opening station. Maximum capacity: up to 500 bags/h.

Pour sacs en polypropylène. Le sac est prélevé par le fond. Un convoyeur à lattes le conduit jusqu'à la station de préhension du sac. Cadence jusqu'à 500 sacs/heure.

TECNO-500

Sequenza operazioni mettisacco - *Bag placing operating sequence* - Séquence du présentateur de sacs



1



2



3



4



5

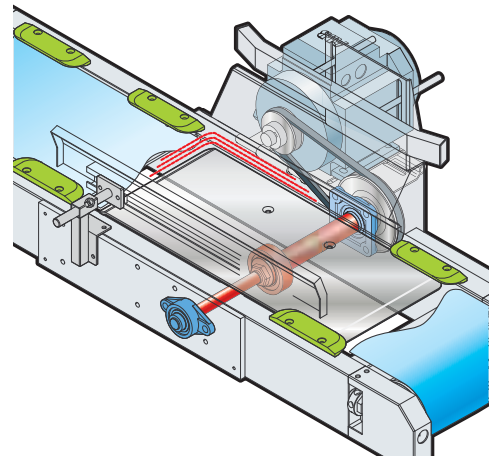

6



7



8

- 1 Preleva sacco
Bag picking
Prélèvement du sac
- 2 Apertura bocca
Mouth opening
Ouverture du sac
- 3 Introduzione su bocca d'insacco
Delivery onto fill spout
Présentation sur la bouche d'ensachage
- 4 Riempimento, bocca sacco posizione alta
Filling, fill spout in raised position
Remplissage, bouche d'ensachage en position haute

- 5 Eventuale vibrazione del sacco dal fondo,
bocca sacco posizione bassa
*Possible vibration of the bag from the bottom,
fill spout in lowered position*
Tassaggio del fondo del sac, bouche d'ensachage en position basse
- 6 Bracci traslatori su bocca sacco
Translating bag top support in position
Conformation et bras de transfert sous bouche d'ensachage

- 7 Bracci traslatori in presa,
ritorno bocca sacco in posizione alta
Bag top supported, fill spout returned to raised position
Fermeture du bras de transfert et remontée de la bouche d'ensachage
- 8 Trasferimento sacco alla linea di chiusura
Bag transfer into closing line
Transfert du sac vers le système de fermeture

Linea di chiusura - Closing lines - Ligne de fermeture de sacs

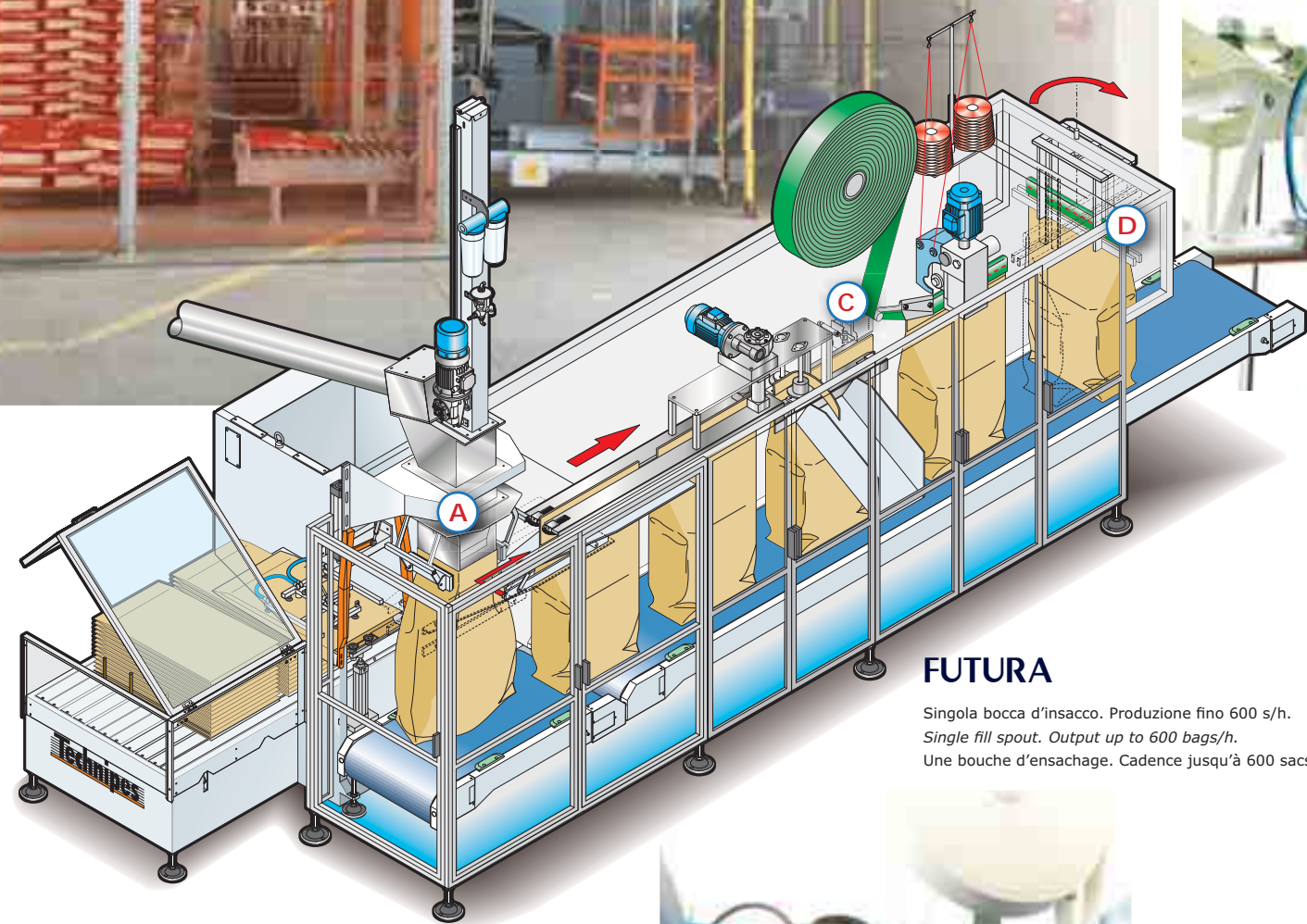

FUTURA

Singola bocca d'insacco. Produzione fino 600 s/h.
Single fill spout. Output up to 600 bags/h.
Une bouche d'ensachage. Cadence jusqu'à 600 sacs/heure.

CART



RIF/PG



BM/AS



RIF/PG/CA



RIF/CC



Linea Futura-HV
Peso netto per sacchi kg 5-50, prodotti granulari/sfarinati, sacco di carta/PP.
Produzione fino a 1100 s/h.

Futura-HV Bagging Line
Net weigh for 5-50 kg bags, granulated/powdered products, paper/PP bags
Output up to 1100 bags/h.

Ligne FUTURA-HV
Pesées nettes pour sacs 5/50 kg, produits granulés/poudre, sacs papier/PP.
cadence jusqu'à 1100 sacs/heure.

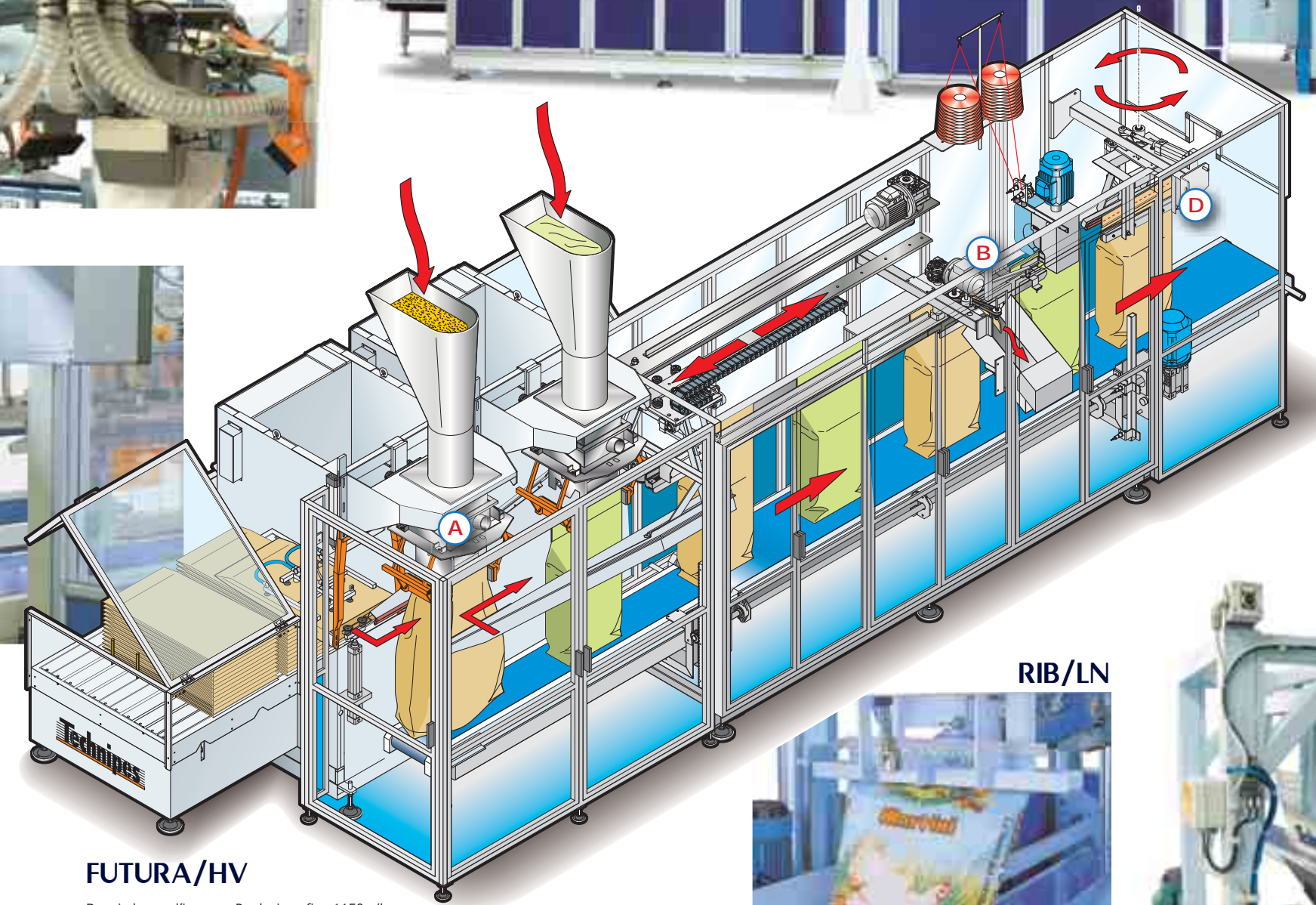
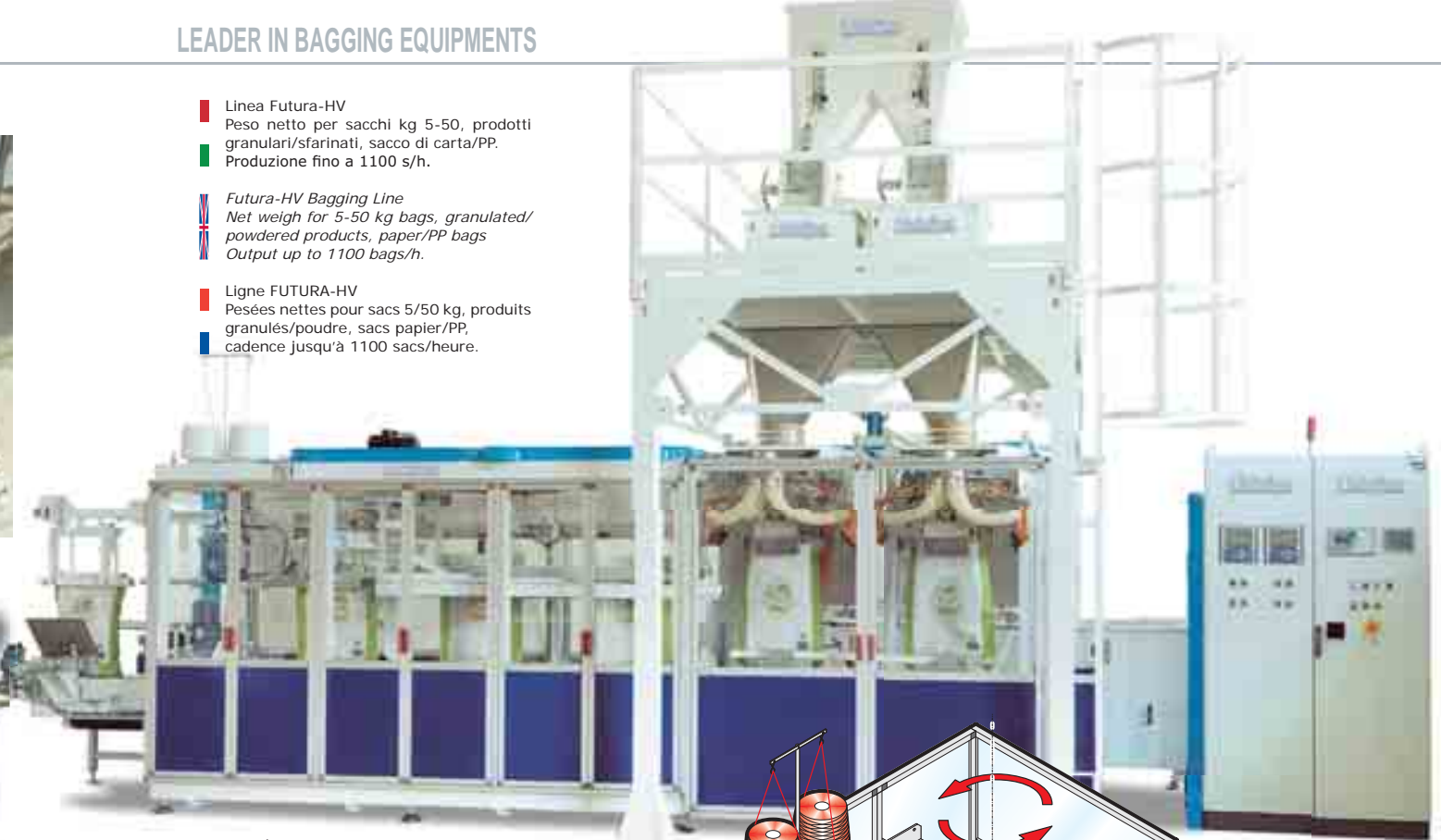

FUTURA/HV

Doppia bocca d'insacco. Produzione fino 1150 s/h.
Possibilità di insacco di due differenti prodotti sia in fase separate sia simultaneamente.
Dual fill spout. Output up to 1150 bags/h.
Possible to package two different products simultaneously or in separate fill phases.
Deux bouches d'ensachage. Cadence jusqu'à 1150 sacs/heure
Possibilité d'ensacher simultanément deux produits différents ou un même produit.

RIB/LN



RIB/90



SA/CC



CART

Gruppo cartellinatore per cartellini preformati.

Tag application device for premade tags.

Etiqueteuse pour dépose d'étiquettes cartonnées prédecoupées.

Dimensioni - Sizes - Dimensions

H	L	Sp
100/120	120/170	min. 140 gr/m ²

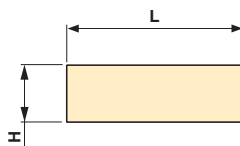

RIF/CC

Per carta crespata con larghezza di 60 mm, a richiesta si può usare carta con larghezza 70 mm. Il sacco viene rifilato per essere predisposto a ricevere correttamente la carta crespata.

Applicator for 60mm wide crepe tape, 70 mm wide tape available on request. The bag top is first trimmed for correct application of the crepe tape.

Pour papier crépon de largeur 60 mm en standard, largeur 70 mm sur demande, arasage du haut du sac pour une parfaite dépose du cavalier crépon sur le sac.



RIF/PG

Il sacco viene rifilato per eseguire correttamente la piegatura, la piega sul sacco viene eseguita in modo continuo senza arresto del sacco.

Bag folding helix forms continuous fold on bag mouth without stopping the bag. The bag top is first trimmed in order to perform folding correctly.

Le haut du sac est arasé pour un bon repliage en continu.



SA/CC

Termosaldatura liner interno PE del sacco più cucitura con applicazione carta crespata a cavagliere.

Bag inner poly liner heat sealing and sewing with application of crepe tape.

Thermosoudure de la sache interne et couture avec dépose de papier crépon en cavalier.



RIF/PG/CA

Rifilatura cimosa del sacco con predisposizione alla successiva fase di doppia piegatura e applicazione di carta preincollata con termosaldatura.

Bag top trimming and double folding, then sealed with application of paper tape with pre-applied glue and heat-sealing.

Arasage, double repliage du haut du sac et application d'une bande papier préencollée, réactivée par thermosoudure.



RIB/90

Gruppo ribaltasacco a spinta 90° per deviazione sacco ortogonalmente.

90° bag kicker unit for perpendicular bag discharge.

Basculeur de sacs pour déviation à 90°.



RIB/LN

Gruppo ribaltasacco a pinza in linea.

Bag turner to lay bags flat for in-line discharge.

Retourneur de sacs à pince en ligne.



BM/AS

Gruppo boccasacco aspirante per consentire di captare tutta la polvere generata dalla funzione d'insacco.

Fill spout dust collection manifold, for vacuum distribution and collection of any dust produced during the bag filling process.

Ensachoir cartérisé regroupant l'aspiration des poussières pendant l'ensachage.



Linee automatiche per sacchi a bocca aperta
Automated closing lines for open-mouth bags - Lignes automatiques pour sacs à gueule ouverte

Futura

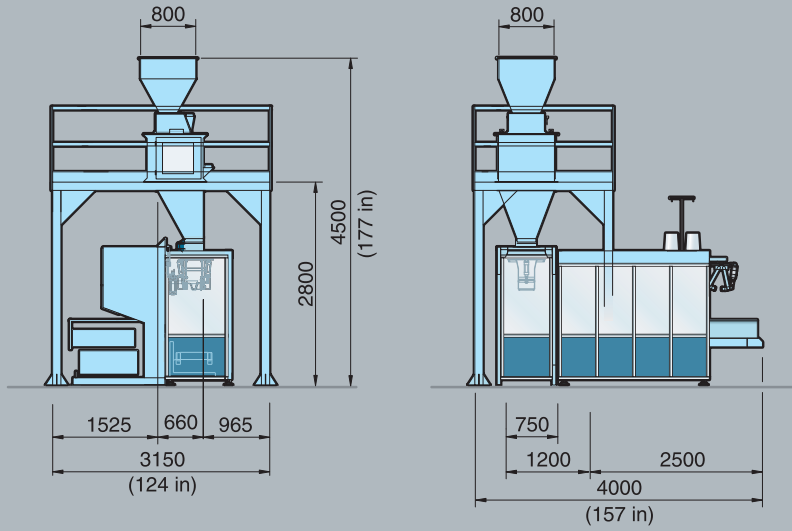

Futura/HV

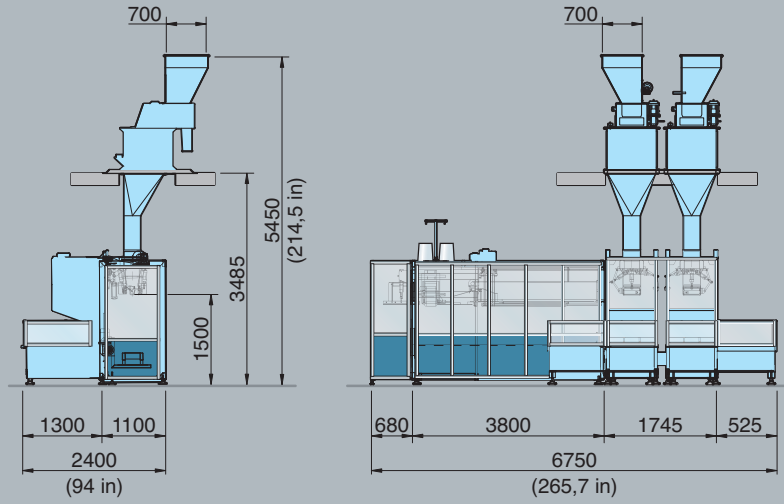

Technipes

WEIGHING
BAGGING
PALLETISING
HANDLING



TECHNIPES s.r.l.
47822 Santarcangelo di Romagna (RN) Italy - via del Gelso, 12 - Phone +39 0541.624.970 - Fax +39 0541.625.902
E-mail: technipes@technipes.com - Web: www.technipes.com